

Advanced Construction Systems Limited

FastClad Building, Granite Close,
Enderby, Leicester LE19 4AE

Tel 0116 272 5133

Fax 0116 272 5131

E-mail info@fastclad.co.uk

www.fastclad.co.uk

Handling, Storage and Installation



DO NOT STACK

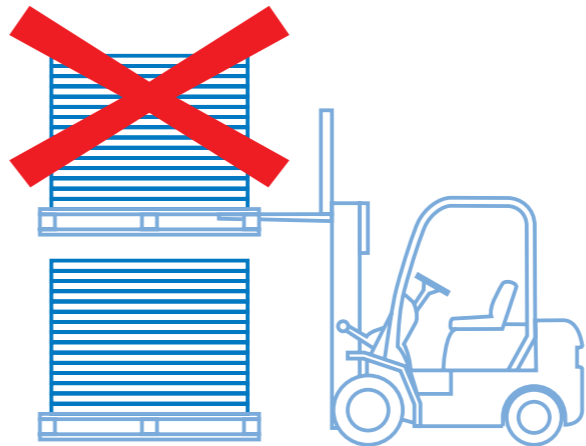

DO NOT SLING

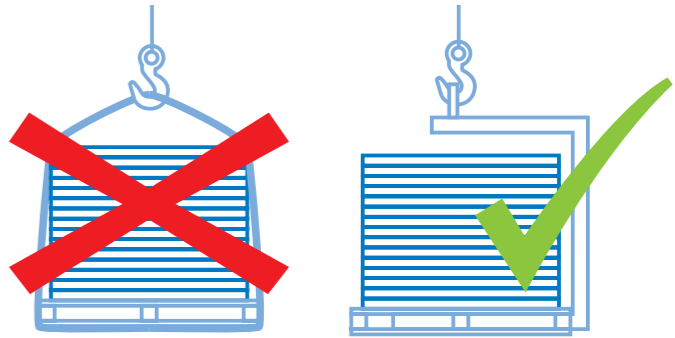

KEEP DRY



STORE ON LEVEL GROUND

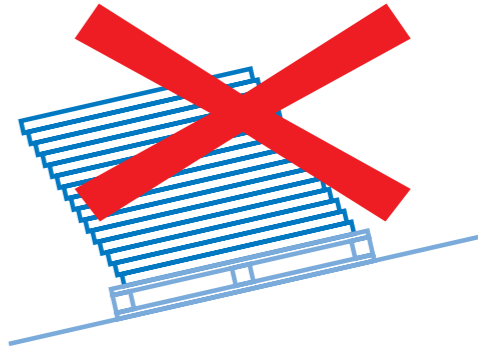

The FastClad system is patent protected.
FastClad is a registered trademark.

Advanced Construction Systems Ltd is registered in England.
Registration no. 5837352. Registered office: Westhaven
House, Arleston Way, Shirley, Solihull B90 4LH
VAT no. GB 110616422



Tel 0116 272 5133
www.fastclad.co.uk



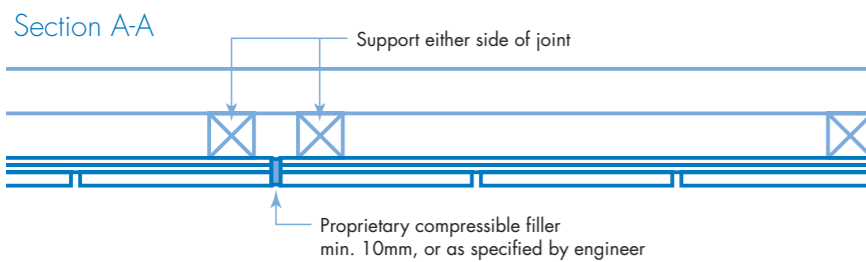
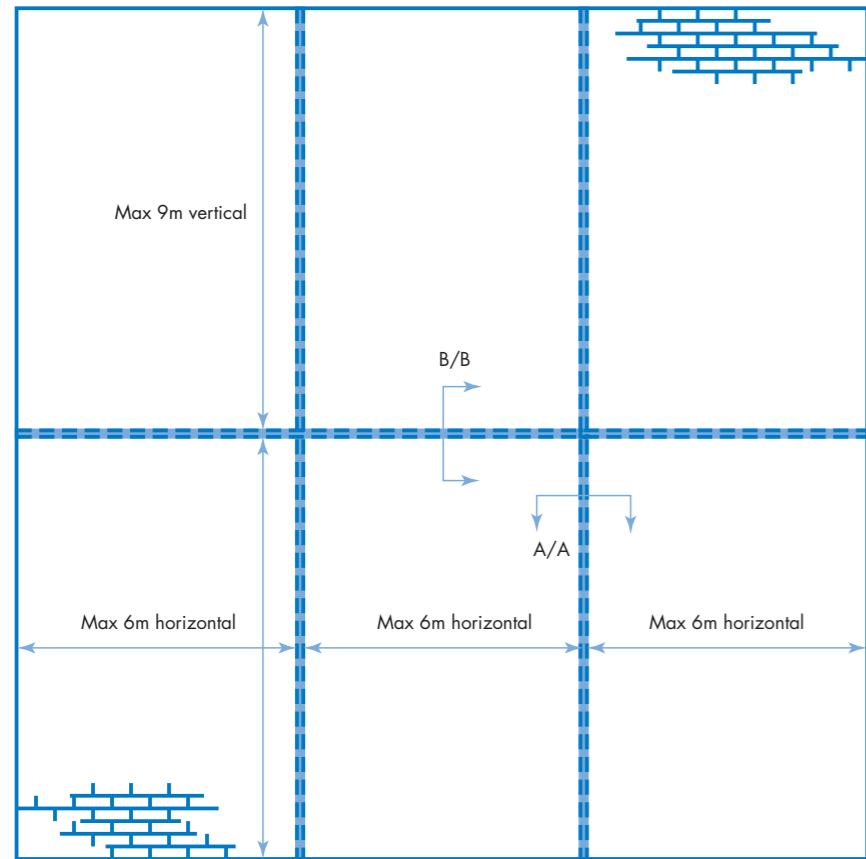

MOVEMENT CONTROL

Maximum 6m horizontally between joints and 9m vertically, unless determined otherwise due to structural movement and subject to engineer calculations.

Section B-B
Additional noggins may be required for fixing through perpendicular joints.

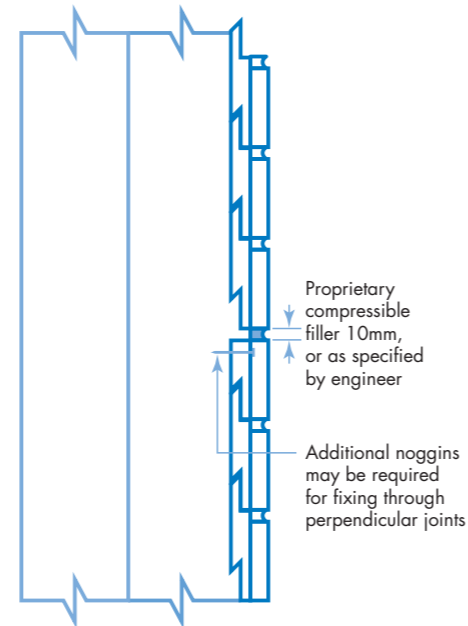

CHECK GAUGE HEIGHT AS YOU PROGRESS

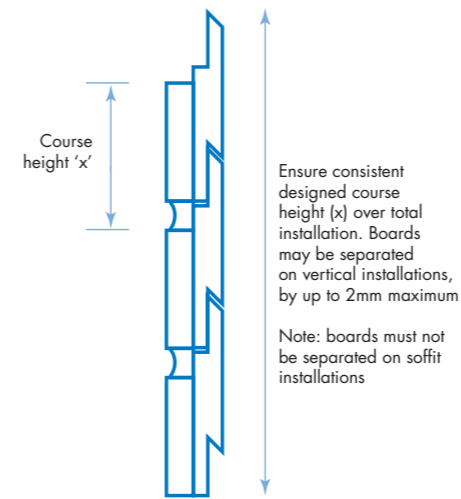

VENTED AND DRAINED

Fastclad is a drained and vented rainscreen system.

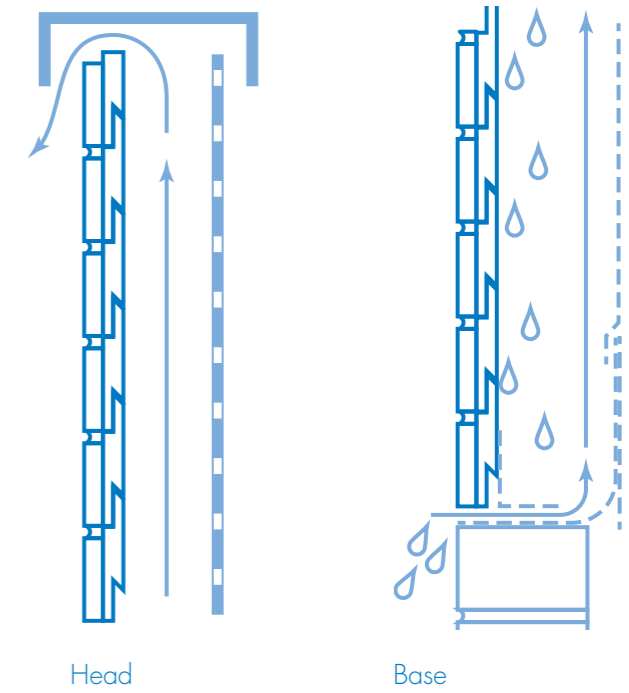

MORTAR JOINT OPTIONS

Mortar must be hydraulic lime to accommodate movement.

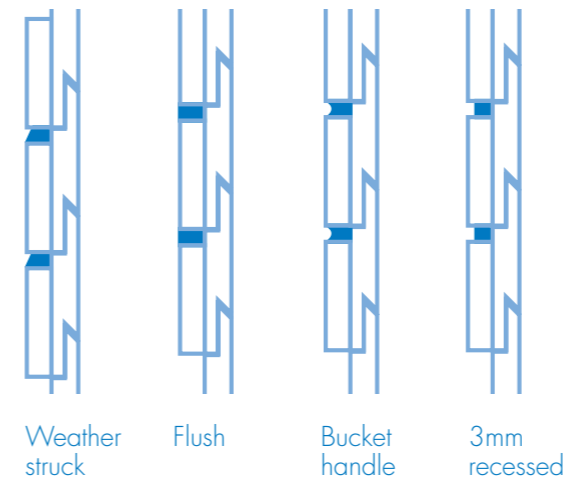

JOINTS

Joints must be well staggered (fix boards to every batten).

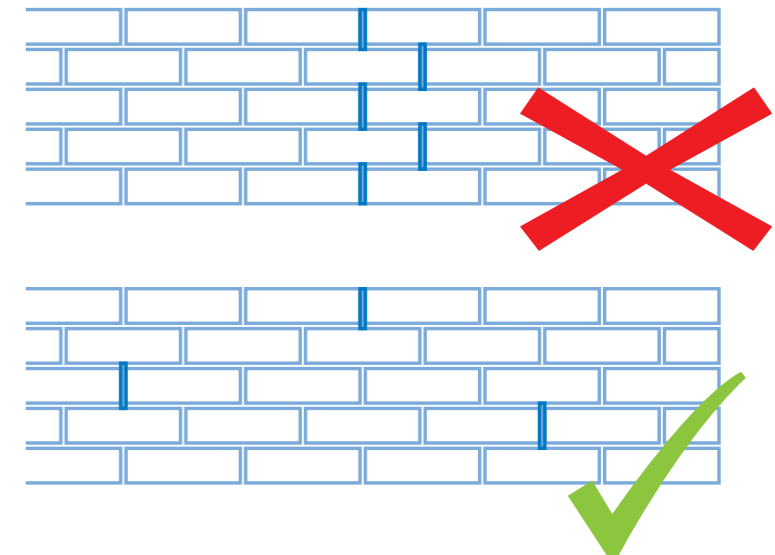

MAXIMUM DISTANCE BETWEEN VERTICAL SUPPORTS

x = Max. 400mm between vertical carrier rails/battens.

